

→ Series 2783

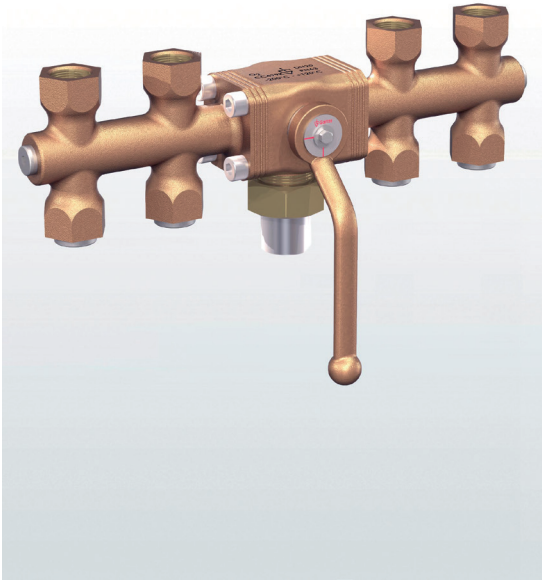

EAC

■ MATERIAL



■ SPECIFICATION



DN 25



- 200°C to + 120°C



PN 63

■ SUITABLE FOR

Liquids	neutral and non-neutral	
Air, gases and vapours	neutral and non-neutral	

■ EXAMPLES OF USE

Diverter ball valve for the installation of for example two safety valves in combination with bursting discs for the protection of containers designed for the storage of cryogenic gases. The requirements of the PED relating to redundant or diverse safety devices are fulfilled by this fitting in combination with safety valves of the 2400 / 2480 series. On each side two additional connections for bursting discs are available. In case the safety valves need to be maintained or the bursting discs replaced, the side requiring maintenance can be shut off.

- For the storage of cryogenic liquified gases, such as LIN, LOX, LAr, CO₂, LNG.
- N₂ in pharmaceutical / foodstuffs applications
- O₂ for medical supply equipment
- CO₂ for foodstuffs/ industrial applications
- LAr for welding
- Cooling plants

The ball-valves are oil- and grease-free as standard. For applications with oxygen (O₂) applicable up to maximum 40 bar and 60°C.

■ APPROVALS

TR ZU 010/2011

Anforderungen

AD 2000-Merkblatt A4
DGR 2014/68/EU

■ MATERIAL

Component	Material	DIN EN	ASTM
Body	Gunmetal	CC499K	CC499K
Internal parts	Stainless steel	1.4404	316L
Primary Seal	PTFE mod.	PTFE mod.	PTFE mod.
Secondary Seal	PTFE	PTFE	PTFE

B01	L-Bore
B02	T-Bore

■ MEDIUM

GF	gaseous and liquid	cryogenic liquified gases, vapours and liquids
-----------	--------------------	--

■ TYPE OF OPERATION

A01	cranked handle made of gunmetal
------------	---------------------------------

■ AVAILABLE NOMINAL DIAMETERS AND CONNECTION SIZES

Nominal diameter DN		20
Inlet		M40x2 (DN25)
Outlet	1/2" (15)	■
	1/2" - 3/4" (15/20)	■
	1/2" NPT (15)	■
	1/2" NPT - 3/4" NPT (15/20)	■

■ TYPE OF CONNECTION INLET / OUTLET THREADED CONNECTIONS

METm / f	Standard	Male thread M40x2 / Female thread BSP-P	DIN 13-7 / DIN EN ISO 228-1
METm / NPT-f		Male thread M40x2 / Female thread NPT-f	DIN 13-7 / ANSI B1.20.1

■ SCREW OPTIONS INLET

VSE1	Screw connection with welding end	DIN EN ISO 1127
VSE2	Screw connection with welding end	ASTM A312 S10
VSE3	Screw connection with welding end	ASTM A312 S40
VLM1	Screw connection with solder nipple	DIN EN ISO 1127
VLM2	Screw connection with solder nipple	ASTM A312 S10
VLM3	Screw connection with solder nipple	ASTM A312 S40
VLM4	Screw connection with solder nipple	DIN EN 12449

All screw fittings include a union nut M40x2.

■ DIMENSIONS AND ORDERING CODE FOR PIPE CONNECTIONS AT THE INLET

Nominal diameter	DN	20
Connection type for pipes according to DIN EN ISO 1127 – dimensions for welding end VSE1	OD x e	26,9 x 2,0
Order code XX		AH
Connection type for pipes according to ASTM A312 S10 – dimensions for welding end VSE2	OD x e	33,40 x 2,77
Order code XX		AY
Connection type for pipes according to ASTM A312 S40 – dimensions for welding end VSE3	OD x e	33,40 x 3,38
Order code XX		AZ
Connection type for pipes according to DIN EN ISO 1127 – dimensions for soldering socket LM1	ID x e	26,90 x 2,00
Order code XX		AH
Connection type for pipes according to ASTM A312 S10 – dimensions for soldering socket LM2	ID x e	33,40 x 2,77
Order code XX		AY
Connection type for pipes according to ASTM A312 S40 – dimensions for soldering socket LM3	ID x e	33,40 x 3,38
Order code XX		AZ
Connection type for pipes according to DIN 12449 – dimensions for soldering socket LM4	ID x e	28,00 x 1,50
Order code XX		BJ

■ NENNWEITEN, ANSCHLÜSSE, EINBAUMAßE

Baureihe 2783: Anschluss, Einbaumaße					
Nominal diameter	DN	20	20	20	20
Connection DIN 13-7	Gi	M40x2 (25)	M40x2 (25)	M40x2 (25)	M40x2 (25)
Outlet	Got / Gob	1/2" (15)	1/2"-3/4" (15/20)	1/2" NPT (15)	1/2" NPT -3/4" NPT (15/20)
Installation dimensions in mm	Cot	28	33	-	-
	Cob	28	28	-	-
	T1	15	15	15	15
	T2/T3	15	15	15	15
	H1	41	41	41	41
	H2	72	72	72	72
	H3	94	94	94	94
	H4	128	128	128	128
	B1	31	31	31	31
	B2	50	50	50	50
	B3	52	52	52	52
	B4	62	62	62	62
	B5 ¹⁾	91	91	91	91
	L1	231	231	231	231
	L2	165	165	165	165
	L3	161	161	161	161
	L4	305	305	305	305
SW1	9	9	9	9	
SW2	36	36	36	36	
K	30	30	30	30	
G4	M10	M10	M10	M10	
T4	10	10	10	10	
α	18°	18°	18°	18°	
Narrowest diameter	d0	16	16/21,5	16	16/21,5
Test port	G1/4	1/4"	1/4"	1/4"	1/4"
Weight	kg	6,2	6	6,2	6,4
Kvs-value	m ³ /h	6,9	6,9 / 12,2	6,9	6,9 / 12,2

¹⁾B5 is equivalent to option VSE2 AY. Other dimensions on request.

■ MAIN DIMENSIONS, INSTALLATION DIMENSIONS

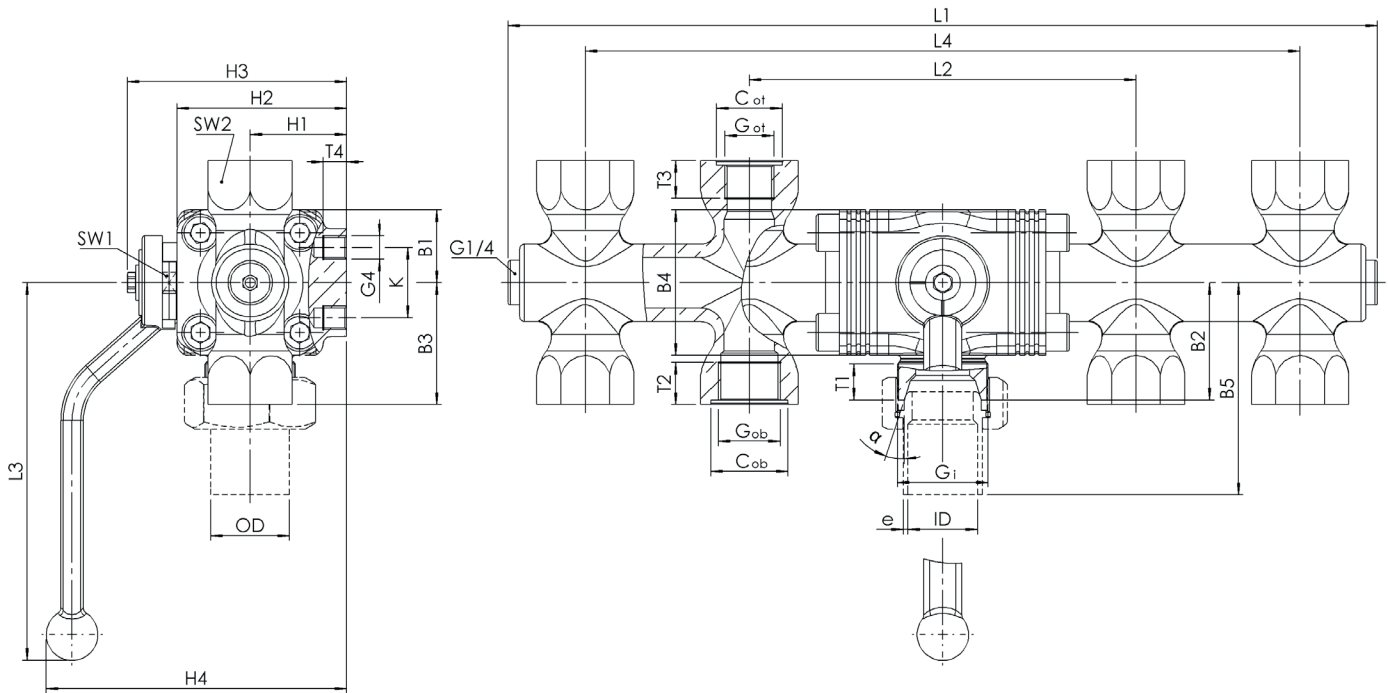

Series 2783 ■ INDIVIDUAL SELECTION / VALVE CONFIGURATION

Series	Ball Version	Medium	Operation	Nominal diameter DN	Connection type		Connection size		Options
					Inlet	Outlet	Inlet	Outlet	
2783	B01	GF	A01	20	METm	f	25	20	
2783	B02	GF	A01	20	VSE2	f	AY	15/20	
2783		GF	A01						
2783		GF	A01						

■ TECHNICAL FINISHES, VARIANTS, ACCESSORIES

S75	fitted with lateral overflow valve DN10 to prevent the activation of the safety valves	<input type="checkbox"/>
S76	fitted with lateral overflow valve DN15 to prevent the activation of the safety valves	<input type="checkbox"/>
A15	Diverter ball valve with shut-off device	<input type="checkbox"/>
		<input type="checkbox"/>

■ CERTIFICATES / APPROVALS

C01	Factory certificate acc. DIN EN 10204 2.2 (WKZ 2.2)	<input type="checkbox"/>	C05	Sealing material manufacturer certification (FDA, USP 3, 3-A...), Please indicate description of certificate:	<input type="checkbox"/>
C02	Test certificate acc. DIN EN 10204 3.1 (WPZ 3.1)	<input type="checkbox"/>	C06	ATEX evaluation acc. to 2014/34/EU	<input type="checkbox"/>
C03	Material test certificate acc. DIN EN 10204 3.1 (MPZ 3.1) (pressure retaining part)	<input type="checkbox"/>	C11	Certification of the production process especially for gaseous oxygen applications by employment of specific materials	<input type="checkbox"/>

■ ADMISSIONS / ACCREDITATIONS

AA4	EAC - certificate/declaration with passport for the valve and laser marking of the valve	<input type="checkbox"/>	AL	Individual inspection by notified body inspector – (body to be indicated):	<input type="checkbox"/>
		<input type="checkbox"/>			<input type="checkbox"/>
		<input type="checkbox"/>			<input type="checkbox"/>

■ ENQUIRY

Copy and send to: order@goetze.de.